

4IGV

www.4igv.cz



Automation of intralogistics

TABLE OF CONTENTS

4 **AUTONOMOUS
PALET AGVs
ROBOMELKUS**

6 **AUTONOMOUS
PALET AGVs
ROBOMELKUS II**

10 **AUTONOMOUS
VEHICLE
ROBOCADDY II**

12 **AUTONOMOUS
VEHICLE
ROBOMECH**

14 **AUTONOMOUS
VEHICLE
ROBOTRUCK**

16 **AUTONOMOUS
FLOOR CLEANER
ROBOCLEANER**

18 **AUTONOMOUS
FLOOR SWEEPER
ROBOSWEEPER**

20 **ADVANTAGES
AND SYSTEMS OF
ROBOTIC DEVICES**

22 **CERTIFICATE
SERVISCONTROL**

23 **WHERE TO MEET
US IN PERSON**

24 **AUTOMATED
WAREHOUSE**

26 **CERTIFICATE
IDEA STORAGE**

28 **AUTOMATED
PALLET
STACKER**

30 **3 STEPS
TO ACHIEVE DYNAMIC
PRODUCTION
AND LOGISTICS**

31 **CASE
STUDIES**



YOUR PARTNER IN AUTOMATION OF INTRALOGISTICS

4IGV has been acting as an integrator and dealer of technologies designed for automation of intralogistics processes. We focus our attention to efficiency and safety of material flow and handling. We help companies deliver goods necessary for production and storage, lower the costs, increase safety and gain time. We offer intralogistics suitable both for smaller and big logistics centres.

Our products include the intelligently guided unattended vehicles (IGV) of ServisControl brand. The vehicles are suitable for production and storage facilities. SLAM, the extremely precise camera navigation, guides the vehicles in space. Their scanners help detect obstacles and drive units provide omnidirectional movement.

We also offer the **high density intelligent automated warehouses**. We shall prepare this warehouse design for you to fit your facility. This concerns a solution where the robots load and unload the automated warehouse stacking system. Mainly: the modular system allows you to save a lot of space, which you would otherwise need for storage.

We shall be happy to show you and explain the specific benefits specifically for your operation in more details. So far, we have implemented a lot of successful solutions allowing us to offer you a reference visit to see it all in a place and ask our clients about their satisfaction and actual benefits.

Our assortment also includes automatic pallet stackers and aligners, including the

automatic storage and unloading system. We also offer the AMR autonomous vacuum sweeper equipped with SLAM navigation capable of integrating into the common fleet management for industrial cleaning and vacuuming floors.

We adhere to the principles that planning and preparation equals 50% success of your project.

In case that you are looking for an experienced partner for automation and maximize effectiveness in the production and storage facilities, you've just found him.

Contact us!

Office address:

4IGV s.r.o.

Vlastibořská 2787/5

P3 logistics parks

193 00 Praha 20

Horní Počernice, Česká republika

+420 732 603 712

+420 732 170 289

+420 605 750 271

obchod@4igv.cz

www.4igv.cz



ROBOMELKUS

flexible pallet AGV for intralogistics

DIMENSIONS

1 664 mm × 604 mm × 2 235 mm

(L × W × H) height without signal mast - 827 mm

POWER DATA

240 mm

max. lift height

1 200 kg

max. load capacity

1,5 m/s

max. speed

SPECIFICATION

Omnidirectional

Drive system

LiFePO₄ / 24 V / 33 Ah

Battery

222 kg

Weight

Length 1300 mm, height 90 mm

Fork dimensions

SLAM Lidar 360° (+/- 10 mm)

Navigation type

577 mm

Total fork width

OFFERED ACCESSORIES

Load fixing frame

2D bar code reader

3D camera

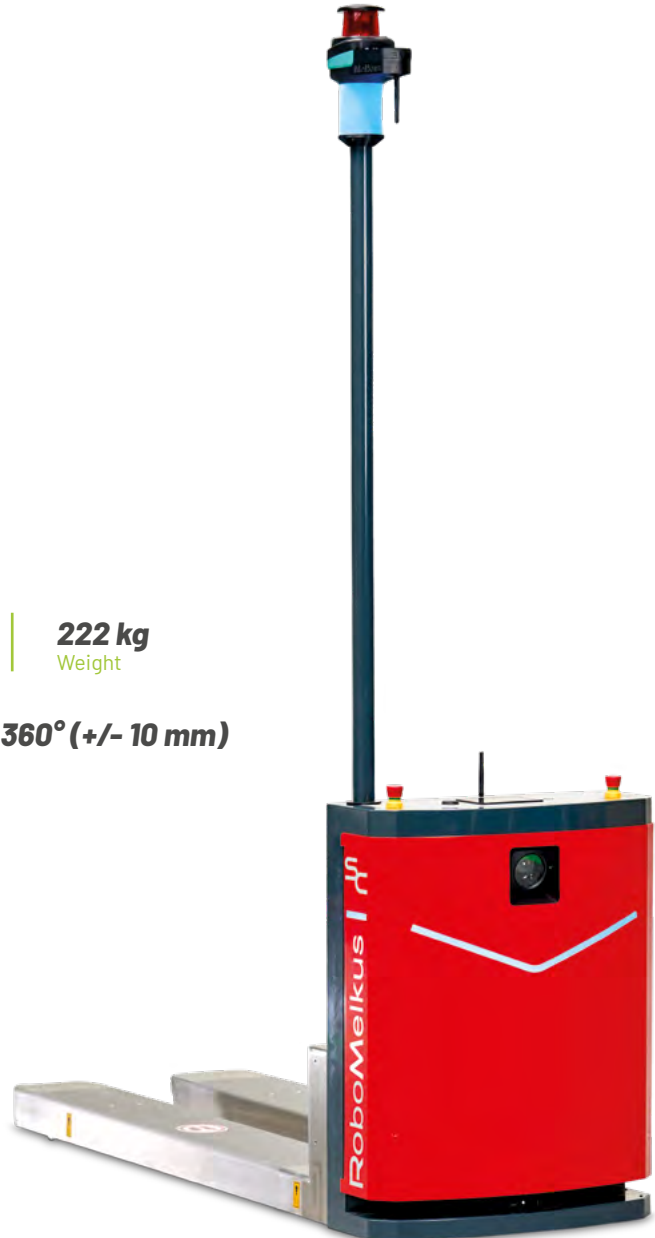

PLEASE READ AS FOLLOWS

AGV low-lift vehicle designed for approaching, lifting and transport both euro and customer-owned pallets, also suitable for transporting other packages and products, if necessary modifications are taken. Pallets can be loaded within the handling space having at least 1.8m and it transports them in height at 250m. The cameras fixed to the lifting forks allow it to recognize the pallet being loaded. RoboMelkus combines the advanced technologies and industry-oriented design.



Flexibility

- The smart omnidirectional steering allows driving in the narrowest spaces.
- Omnidirectional free range of movement.
- The smart devices also control operation and diagnostics.
- Ease integration into the existing systems (REST API, MQTT, VDA 5050).
- SLAM navigation.



Efficiency

- Transverse movement allows for shorter track.
- High-performance LiFePo4 batteries make possible 4 hours operation from full charge. Short charging times.
- Energy efficiency due to low nett weight.



Features

- 4.3" touch panel.
- Status LED semaphore on the laser mast.
- Safety light arrow.
- Laser-supported pallet search.



Intelligence

- Laser scanner allows for high staff security.
- Compact automation solution by SIGMATEK.
- WLAN communication using the guidance system.
- The smart drive allows for careful material transport and low floor wear.
- Flexible tasks creation.



Area of use

- Point-to-point load transport.
- Transportation within the restricted space.
- Material and workpieces transport within the production process.
- Logistic storage and transport to operating premises.

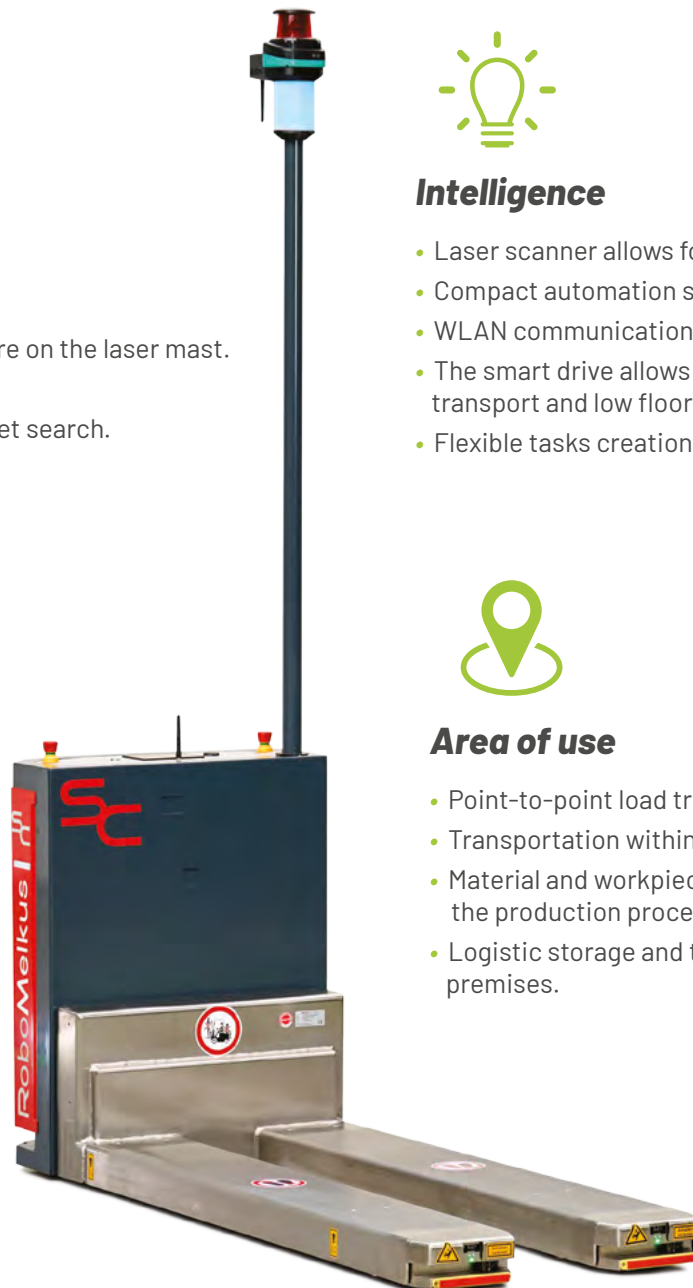

ROBOMELKUS II

flexible pallet AGV for intralogistics

DIMENSIONS

1 700 mm × 800 mm × 2 236 mm
 (L × W × H) height without signal mast - 1,721 mm

POWER DATA

800 mm max. lift height	1 300 kg max. load capacity	1,5 m/s max. speed
-----------------------------------	---------------------------------------	------------------------------

SPECIFICATION

Omnidirectional Drive system	2x LiFePO4 / 24 V / 75 Ah Battery
--	---

400 kg Weight	Length 1200 mm, height 90 mm Fork dimensions
-------------------------	--

577 mm
Total fork width

SLAM Lidar 360° (+/- 10 mm)
Navigation type



OFFERED ACCESSORIES

Load fixing frame	2 additional batteries	Assembly of other sensors
2D bar code reader	3D camera	



Flexibility

- The smart omnidirectional steering allows driving in the the narrowest spaces.
- Omnidirectional free range of movement.
- The smart devices also control operation and diagnostics.
- Ease integration into the existing systems (REST API, MQTT, VDA 5050).
- SLAM navigation.



Features

- 4.3" touch panel.
- Status LED semaphore on the laser mast.
- Safety light arrow.
- Laser-supported pallet search.
- Other sensors on request (bar code reader, 3D camera, etc.).



Efficiency

- Transverse movement allows for shorter track.
- High-performance LiFePo4 batteries make possible 4 hours operation from full charge. Short charging times.
- Energy efficiency due to low nett weight.
- Wireless charging option.
- The freely suspended lifting fork facilitates load handling.
- High-performance LiFePO4 power sources include 1.8 kWh battery, 2x
- Always ready to use due to innovative wireless charging technology.



Intelligence

- Laser scanner allows for high staff security.
- Compact automation solution by SIGMATEK.
- WLAN communication using the guidance system.
- Careful material transport and low floor wear using the smart drive technology.
- Flexible tasks creation.



Area of use

- Point-to-point load transport.
- Transportation within the restricted space.
- Material and workpieces transport within the production process.
- Logistic storage and transport to operating premises.

ROBOMELKUS

Driving surface finish (free of side scanners)

Load carrier	A	B	C	D	E	F	G	H	I	J
Europallet 1200 × 800 mm	1100 mm	1500 mm	2500 mm	3200 mm	1800 mm	2100 mm	2500 mm	100 mm	100 mm	100 mm

*automatic lowering not allowed

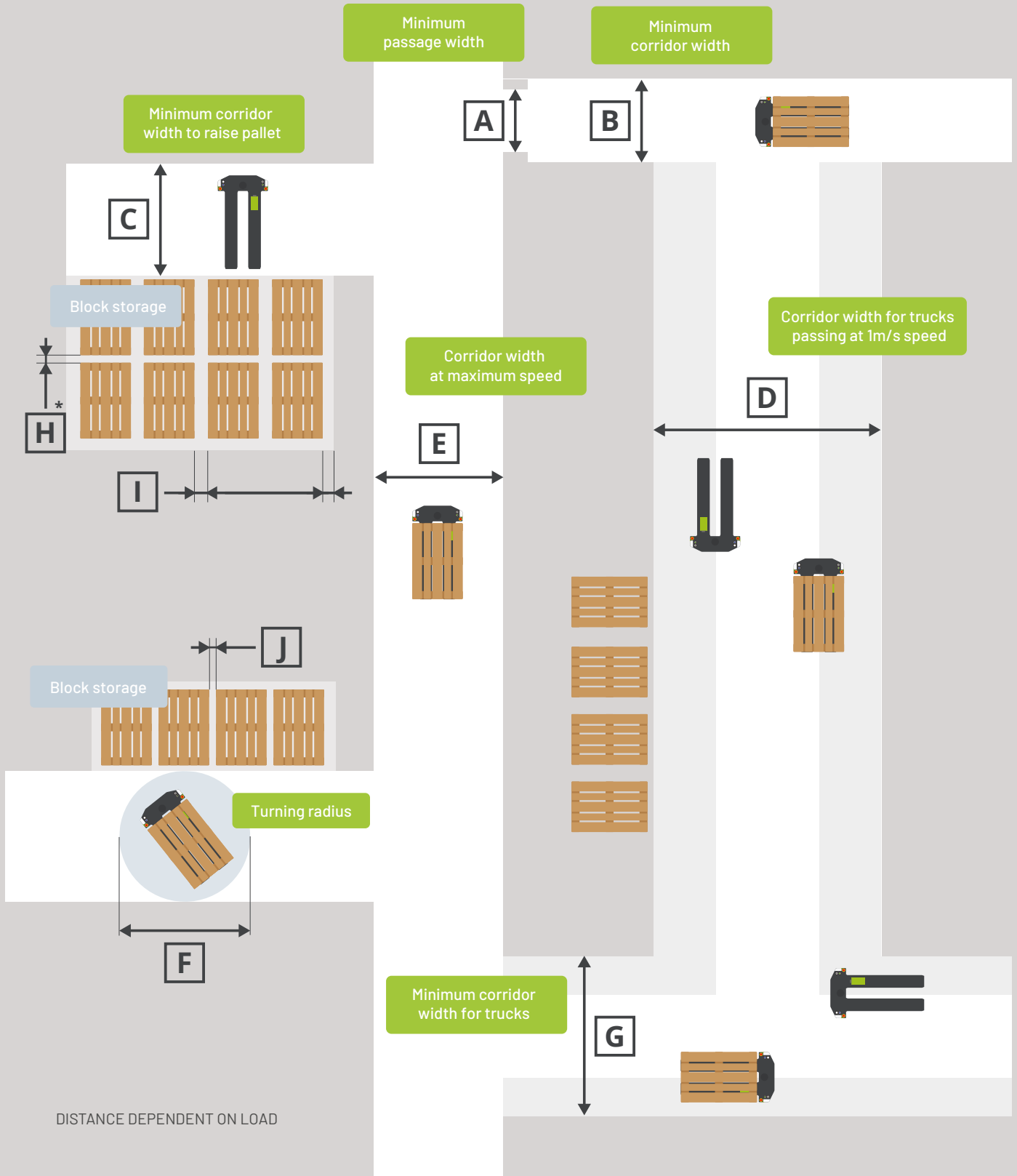

ROBOMELKUS



ROBOCADDY II

AGV/AMR autonomous vehicle with variable platform

DIMENSIONS

700-1 200 mm × 410-450 mm × 837 mm/262 mm
(L × W × H)

POWER DATA

60 mm
max. lift height

100 kg
max. load

1,2 m/s
max. speed



These AGV/AMR vehicles are designed exactly according to the specific customer application needs. AGV/AMR RoboCaddy II can be equipped with the robot, roller conveyor, belt conveyor or other superstructure type.

SPECIFICATION

Bi-directional/differential
Drive system

LiFePO4 / 24V/40 Ah
Battery

70-200 kg
Weight

N/A
Towing device

Scanner 270°, 1-2x/Safety bumpers, 2x
Safety device

Contactless charging dock, 24V/20A
Charging dock

Belt conveyor, roller conveyor, robot
Superstructure type

Magnetic strip / SLAM / QR Code
Navigation type

SUPERSTRUCTURE TYPE

- belt conveyor
- roller conveyor
- robot

Example of customer vehicle.



BASIC CONFIGURATION WIDTH 450 MM

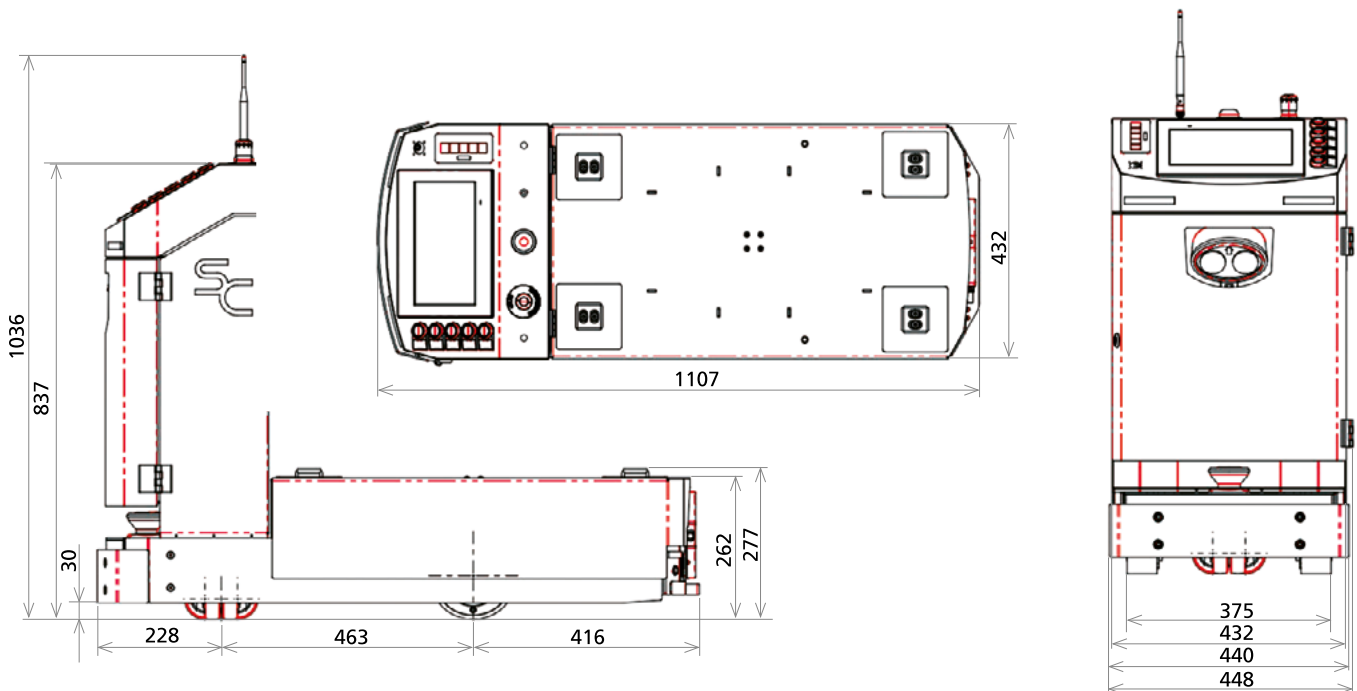

ROBOMECH

AGV/AMR autonomous vehicle with variable platform

DIMENSIONS

1600-2 000 mm × 600-900 mm × 280-300 mm
(L × W × H)

The mecanum wheels-equipped chassis allows RoboMec to move in all directions, including the crab one in real time and turning around its axis.

POWER DATA

25-65 mm
lift height

400-750 kg
max. load capacity

1,2 m/s / 0,5 m/s
max. speed/speed at full load



SPECIFICATION

Omnidirectional/mecanum drive wheels, 4x
Drive system

LiFePO4 / 48 V / 40 Ah
Battery

300-400 kg
Weight

N/A
Towing device

Magnetic strip / SLAM / QR Code
Navigation type

Contactless charging dock, 48V / 20A
Charging dock

Belt conveyor, roller conveyor, robot
Superstructure type

Scanner 270°, 2-3x/Safety bumpers, 2-4x
Safety device

AUTONOMOUS VEHICLE ADVANTAGES

- orientation using SLAM navigation
- obstacle detection
- omnidirectional movement
- goods and load autonomous transportation
- load capacity up to 1300kg
- lift height 800mm
- LiFePO4 battery – 4 hours operation at full charge



SUPERSTRUCTURE TYPE

- belt conveyor
- roller conveyor
- robot

These AGV/AMR vehicles are designed exactly according to the specific customer application needs. AGV/AMR RoboMec can be equipped with the robot, roller conveyor, belt conveyor or other superstructure type.

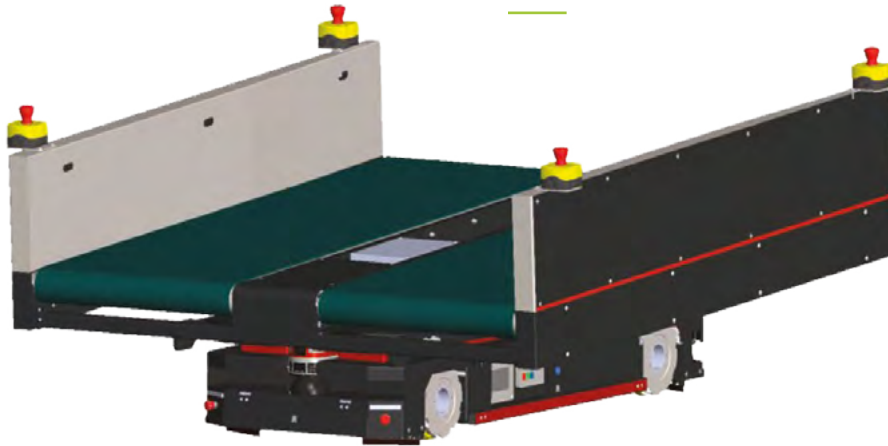

WIDTH BASIC CONFIGURATION 600MM

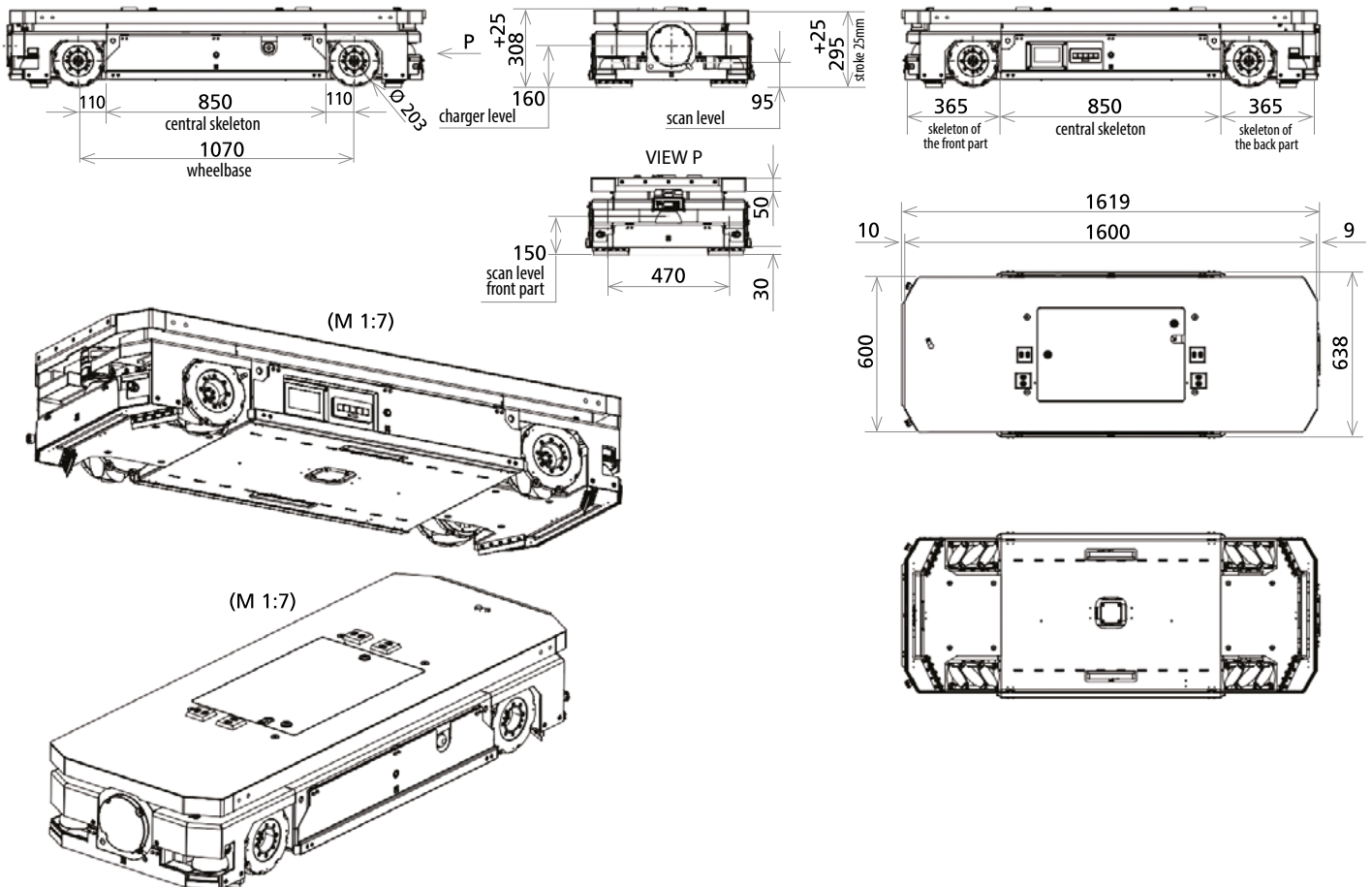

ROBOTRUCK

AGV/AMR autonomous vehicle designed for towing the wagon sets

DIMENSIONS

1200 mm × 600 mm × 900 mm
(L × W × H)

30 mm
headroom

POWER DATA

3000 kg / 5000 kg
Towing device/Towing device with additional load

1,2 m/s
max. speed



SPECIFICATION

Bi-directional / differential
Drive system

LiFePO4 / 48 V / 80 Ah
Battery

IP 20
IP class

10-45 °C
Ambient temperature

Magnetic strip / SLAM / QR Code
Navigation type

Contactless charging dock, 48V/20A
Charging dock

Automatic train connection (using the camera)
Superstructure type

Scanner 270°, 1x
Safety device

ROBOMELKUS
flexible pallet AGV
for intralogistics



BASIC CONFIGURATION

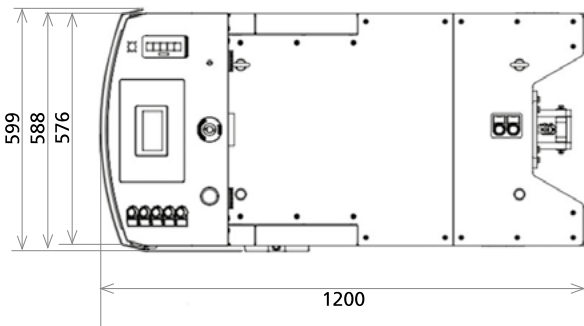
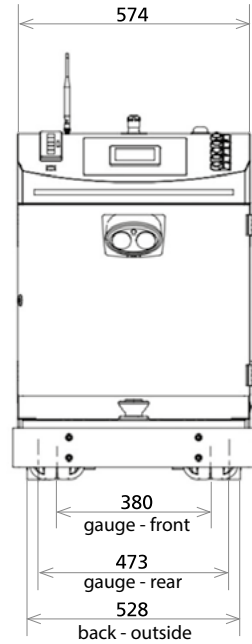
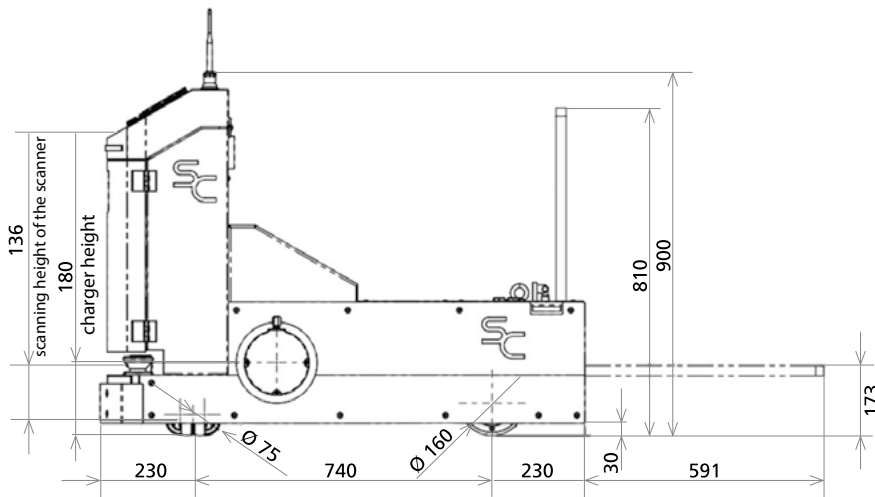

AGV/AMR RoboTruck can be modified according to the customer's needs. AGV/AMR RoboTruck can be retrofitted with automatic train coupling and uncoupling using a camera.

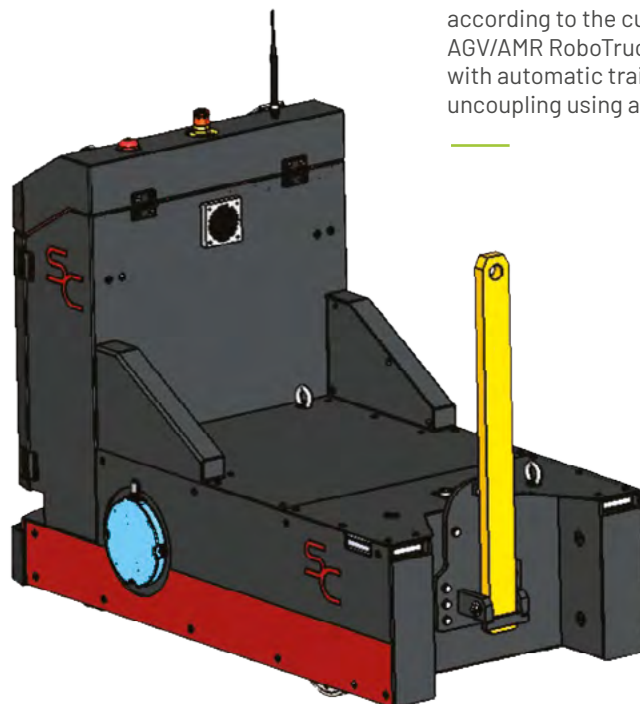

ROBOCLEANER

AMR flexible floor sweeper suitable for logistics, industry, public areas, etc.

DIMENSIONS

1267 mm × 827 mm × 1067 mm
(L × W × H)

700-750 mm
Cleaning width/collector width

RoboCleaner, as one of the few on the market, meets the standard for automatic floor sweepers, for commercial use EN IEC 63327.

POWER DATA

1,1 m/s
max. speed

USEFULL PROPERTIES

60 l Fresh water | **55 l** Waste water | **2 l** Detergent tank

2 750 m²/h
Max. cleaning power



SPECIFIKACE

Bi-directional Drive system | **Li-ION / 24 V / 120-180 Ah** Battery | **IP 20** IP class | **10-45 °C** Ambient temperature | **260 kg** Weight

SLAM Lidar Navigation type | **Part of S700C service station** Charging dock | **S700C service station** Supplement

Safety laser scanner
Safety device

S700C SERVICE STATION

366 mm × 986 mm × 911 mm (L × W × H) | **37 kg** Weight | **230 V** Electrical energy | **3/4" min. 3 max. 6 bar** Water connection



AUTONOMOUS OPERATION

- Cleaning robot operation is completely self-sufficient even without connecting to WIFI network.



NAVIGATION USING BUILT-IN SOFTWARE PLATFORM

- The unique software interacts with the sensors providing high navigation stability and reliably prevents collisions.
- The machine, as one of the few on the market, meets the requirements of EN IEC 63627.



AREAS OF USE

- Industrial production operations.
- Logistic centres.
- Public buildings.
- Sports hall.



USER INTERFACE

- The intuitive touch screen, operated even by a worker without much knowledge, controls the system.
- It is equipped with the multilingual user interface.
- The cleaning programmes are capable of automatic launching for individual days of the week. If needed, the staff can manually run any washing programme.



SUITABILITY FOR INDUSTRIAL USE

- The cleaning robot has undergone CE certification for industrial use.
- It is equipped with the high-quality components, stainless steel parts, maintenance-free brushless motors.



CLEANING CLOSE TO THE EDGE

- The additional brush sweeps dirt and particles towards the main roller which transports them into the collection container.



FULL AUTONOMY WITH STOP IN THE SERVICE STATION

- Battery automatic charging.
- Automatic replenishment of clean water.
- Automatic waste water discharge.



ROBOSWEEPER

AMR flexible floor sweeper suitable for logistics, industry, public areas, etc.

DIMENSIONS

1700 mm × 1300 mm × 1500 mm
(L × W × H)

RoboSweeper, as one of the few on the market, meets EN IEC 63327 standard for automatic floor sweepers for commercial use.

POWER DATA

1,1 m/s
max. speed

SPECIFICATION

Bi-directional
Drive system

Li-ION / 24 V / 180-480 Ah
Battery

IP 20
IP class

10-45 °C
Ambient temperature

485 kg
Weight

SLAM Lidar
Navigation type

Charging dock 24V
Charging dock

S1300 service station
Supplement

Safety laser scanner
Safety device

5 000 m²/h
Max. cleaning power



S1300 SERVICE STATION

3 500 mm × 2 000 mm × 2 000 mm
(L × W × H)

240 kg
Weight

230 V
Electrical energy

1100 l
Waste container



AUTONOMOUS OPERATION

- Fully automated vacuum sweeping robotic system is equipped with service station used to charge the robot batteries. In addition, the system offers automatic disposal of swept dirt that can be dumped into a standard container.
- The vacuum sweeping robotic system was specially developed for logistic and industrial areas to effectively remove coarse dirt in big halls or warehouses.
- The vacuum cleaner turns on the spot and it can also be used for cleaning in the confined spaces.
- The robot is capable of overcoming the ramps with a slope of up to 20%.



AREAS OF USE

- Industrial production operations.
- Logistic centres.
- Public buildings.
- Commercial centres.
- Car parks.



TRANSPARENT ACTIVITY DOCUMENTATION

- After each use of the service robots, the fully automated reporting facilitates documentation and service verification for billing purposes, preparation of performance records or audits.
- The possible monitored quantities of cleaning, washing time and other details.
- The cleaning documentation has been certified and meets the data protection requirements.



DATA PROTECTION IN ACCORDANCE WITH GDPR*

- Privacy protection - the cleaning robot contains neither personalized nor environmental data.
**General data protection regulation 8*



HIGH LEVEL OF SAFETY

- A combination of different smart sensors ensures navigation high stability and brings collision avoidance to a performance level that corresponds to IEC 63327 safety standard.
- This increases independence and autonomy of ADLATUS systems and ensures safety even in the environment where many people are present.



AGV/AMR ensures transportation of goods and loads using the autonomous unmanned handling machinery. The use, maintenance or new configuration allows the machinery fleet to be easily and seamlessly distinguished.

ADVANTAGES OF ROBOTIC DEVICES



Transportation control system that avoids collisions



The number of IGV may increase in proportion to production processes



Delivery just-in time



Upgrade without equipment downtime



No errors at the destination



Easy route configuration or adding new machines to be served



Inventory management greater efficiency



The AGV/AMR vehicles do not harm goods, machinery or fixed structures



Low operating costs



The work flow has been distributed among the AGVs themselves in an efficient and dynamic manner



Operation 24/7



The transport flow effective optimization depending on the number of vehicles available, transportation conditions and tasks



5G technology



Compatibility with any automation type



Error rate and harmful events elimination



Saving labour costs, transfer of workers to more qualified jobs



It ensures maximum safety in operation



Easy integration into the existing customer's processes and structures



Quick return on investments

TRAFFIC CONTROL SYSTEM

- The TCS fleet management system manages the shipping orders from the external system, for instance ERP and converts them to AGV.
- The AGV traffic control system ensures processing the orders as quickly and efficiently as possible.
- It has also been capable of communicating with the external hardware, such as fire doors, sliding door, PLC installed base, etc.

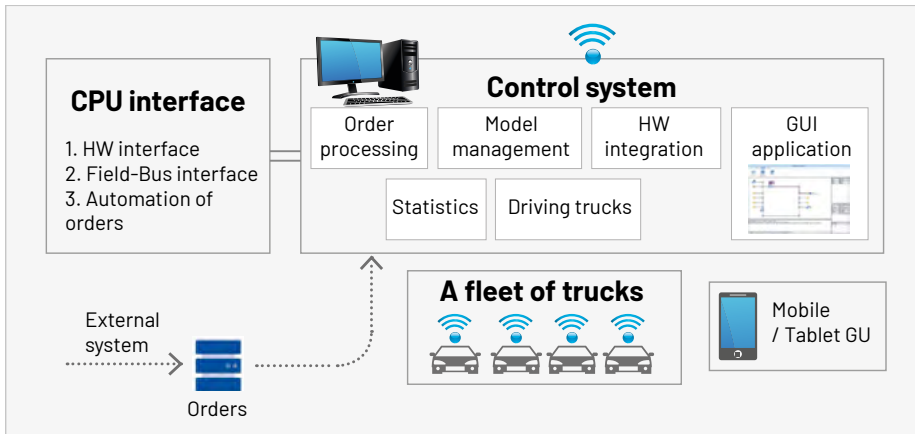

AGV/AMR SPECIFICATION AND PROPERTIES



SAFETY SENSORS

- AGV/AMR meets all the safety standards according to EN 3691-4, EN 12100, EN 13849-1, EN 13850 and EN 13855AGV. Sensors number as needed.
- We, as a manufacturer, can adjust the vehicle safety according to needs and application.



FLEET MANAGEMENT

- The safety PLC (ready for VDA 5050 protocol) controlled industrial fleets.
- Optional wireless safety communication in PL d category.
- Fleet sensor management using the logistic advanced features.
- Communication and connection with the other systems at the customer.



COMMUNICATION WITH THE CUSTOMER NETWORK

- Our system communicates using the customer network via Wi-Fi or 5G. An option to use encrypted communication along with TLS data exchange.
- We can generally meet the most stringent customer's IT requirements.



SUPERSTRUCTURE FOR AUTONOMOUS VEHICLES

- The customer superstructure according to needs and application - lifting mechanism, robot, conveyor, special system.
- Moving and driven parts powered and controlled directly from AGV/AMR.



CERTIFICATE

ServisControl s.r.o.

hereby certifies that

4IGV s.r.o., Czech Republic

It has been capable of providing tutorial, installation and support services for ServisControl, as well as a commitment to continuous education, therefore it has been certified as **ServisControl PARTNER** for 2024.

A blue ink signature of Zdeněk Šibrava.

Zdeněk Šibrava

ServiceControl, s.r.o. Company Executive

Issue date: August 01, 2024

CERTIFICATE

WHERE TO MEET US IN PERSON

There have been a lot of opportunities to meet us. You will get more familiar with our technologies at all meetings. We will be happy to visit you or we can talk during the events, such as logistics conferences, where we and other experts will provide you with an overview of the up-to-date trends in the field of logistics.



We visit both the customers and, of course, companies where we introduce our technologies. After the presentation, we shall go straight to the production plant and, on the spot, we shall tell you whether the technology is suitable or not for your company. We offer the solution directly tailored to you. To make a final decision, we shall individually process the relevant details with clearly quantified benefits for you.



For instance, you could meet us at the Trends in Automotive Logistics conference.

Our 4IGV company regularly attends the EASTLOG logistics conference.



You can also visit our exposition at the International Engineering Fair, Brno.

We also organize our own conferences.



For more information, please visit our website

AUTOMATED WAREHOUSE

THE ROBOTIC WAREHOUSES SAVE THE TIME, SPACE AND NEED FOR HUMAN INTERVENTION



SPECIFICATION

- We shall personalize both the structure and number of robots following the season and current workload.
- Less inter-warehouse transfers, less energy.
- Operation 24/7.
- We have been capable of converting up to 90% warehouse cubic capacity to logistic system and thus double its capacity.

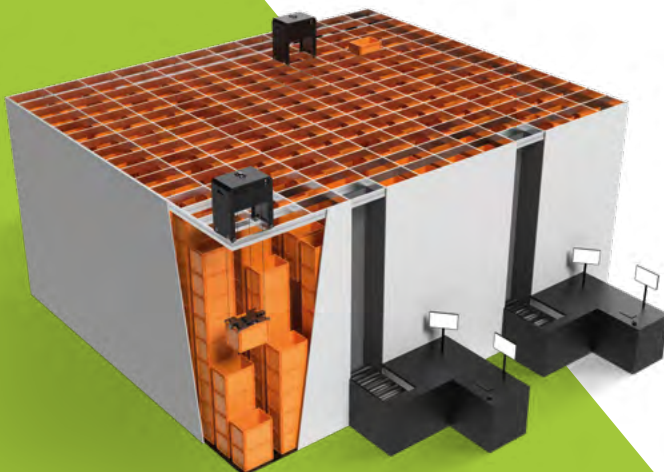

CONSTRUCTION

- Aluminium profiles network which fits together using the locks. The structure top rails enable the movement of the robots.
- The installation has been tailored to the warehouse size and capacity.
- Structure/grid up to 8.2m + space for robot.
- This allows you to add and remove the new profiles.
- Easy adaptation to the season requirements.

ROBOTS

- They operate on the fixed structure top.
- They move boxes similar to the elevator.
- They charge independently and operate 22 hours per day



TRANSFER AREA

- IN/OUT as much as you need.
- Within the transfer area, all movement can be monitored and recorded in the real time.
- The box itself never has to leave the structure.
- The number and transfer areas location are flexible
- The open table allows easy goods handling.
- Full integration into the control system.

BOX

- The robots can work with any boxes.
- We shall provide your systems with the EAN codes enabling you manage according to the specific products categories.
- DIMENSIONS: 600mm x 400mm.
- Variable Height: 120-420mm.
- The mounting plate can be adapted for a specific box type.
- The possibility of using own boxes.
- The KLT boxes can leave the automated storage system.



CONTROL SYSTEM

- It passes instructions to robots.
- It optimizes the processes and integrates into your ERP.
- It monitors and saves all data in real time.
- The wireless connection operates even without Wi-Fi.
- It enables remote configuration, service and support as well.



HIGH-DENSITY STORAGE BENEFITS

- maximum grid height: 8.2m + space for robot
- variable height for boxes in a single column: 120-420mm
- the boxes can leave the automated storage system
- the possibility to use own boxes
- the number of transfer areas as needed
- robot load capacity up to 30kg

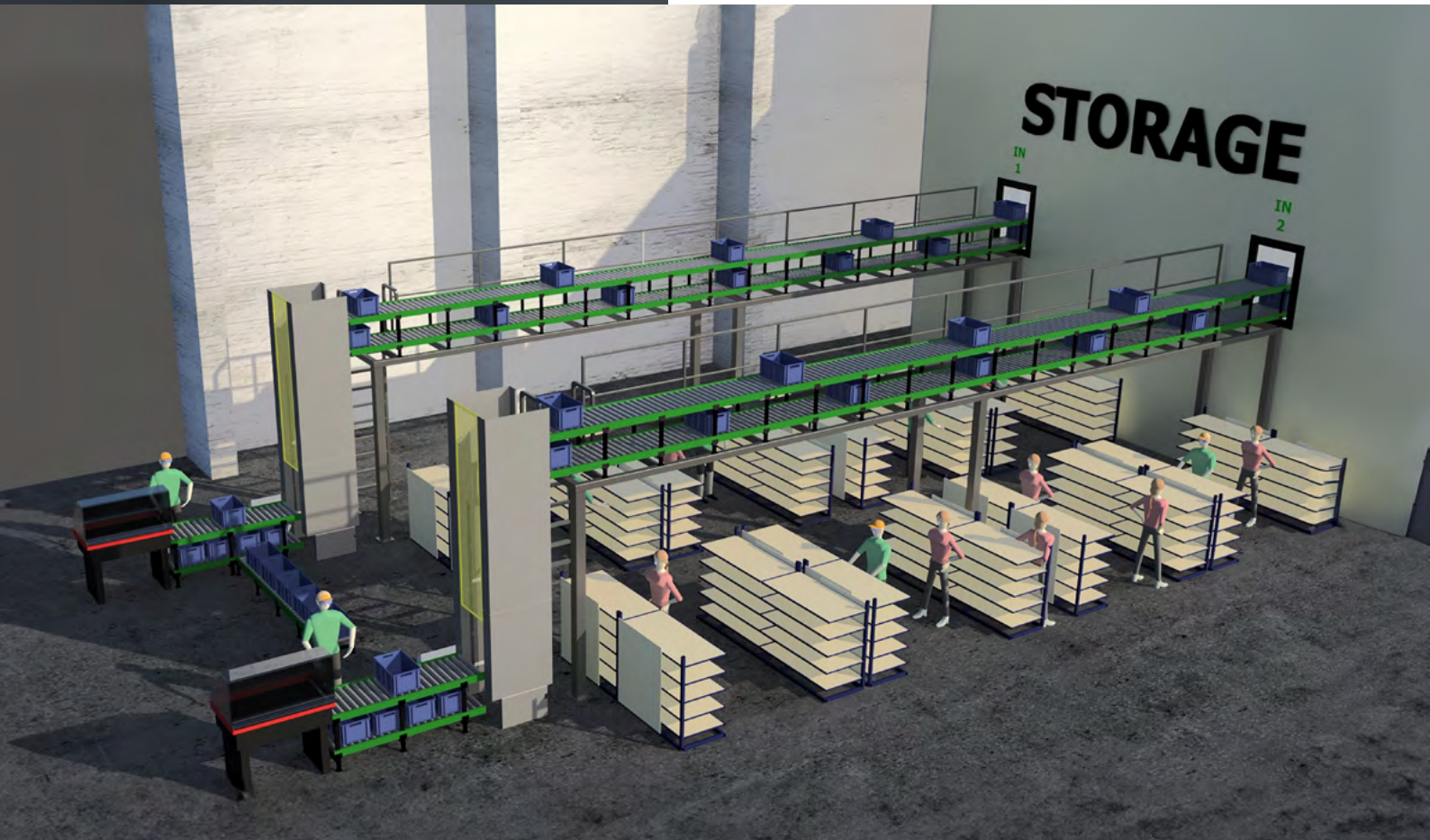



CERTIFICATE

IDEA STORAGE SERVICES s. r. o.

confirms that

4IGV s. r. o., Czech Republic

demonstrates the competence to provide consultation, installation and support services for IDEA STORAGE SERVICES, as well as a commitment to further education, and is therefore certified as an IDEA STORAGE SERVICES SYSTEM INTEGRATOR for the year 2024.

Release date: December 1, 2023

A handwritten signature in orange ink, appearing to read "Rudolf Blažek".

JUDr. Rudolf Blažek
CEO

AUTOMATED PALLET STACKER

FOR PALLET EFFECTIVE FLOW

We offer the separate automated pallet stacker units that automate handling empty pallets at the floor level. This significantly streamlines the entire stacking and unloading procedure and, at the same time, protects employees from health risks related to manual lifting of heavy objects. Moreover, the pallets are inserted and removed from the lower level which enables the automated vehicle (or the operator-controlled one) that with an operator) not to waste time with lifting the forks.

BENEFITS



Simple control



Reduced time spent handling pallets



Workplace increased safety



Floor area saving



Eliminated manual handling pallets



Pallet flow streamlining



Less burden on worker



Pallet costs savings



Restrictions on trailer use



- **Capacity** 15 or 25 pallets
(this comprises a wide range of pallets: all wooden, plastic and metal four-way pallets, no matter their dimensions).
- Either fully automated or semi-automated stacking and unloading procedure.
- **Insertion or removing pallets** using the stacking vehicle, forklift vehicle, AMR or IGV (1-5 pallet, 1+1 pallet two in a row according to the stacker type).
- It requires **230V power** supply.
- It works entirely on alternate current or compressed air.
- The stackers powered by alternate current are also suitable for handling pallets in cold storages with a temperature of **up to -25°C**.
- It also uses the photo sensors for detection.
- **The interface with the touch screen** enables switching among the stacking and unloading modes.
- The feature is capable of setting:
 - removing** - stack of 15-25 pallets is inserted into the stacker and afterwards they are fully automatically removed,
 - stacking** - one pallet after another is inserted into the stacker, 15-25 pallets are automatically stacked and the entire stack can then be unloaded.

OUR UP-TO-DATE TECHNOLOGY REPRESENT OUR ADVANTAGE



3 STEPS TO DYNAMIC PRODUCTION AND LOGISTICS

- Are you looking for a solution to effectively digitalize your production and logistic processes?
- Would you like to get the most out of your human resources and be ready to transform into a full automation?
- Cooperate with us. Cooperation with a wide portfolio of our expert partners will allow us to prepare a solution which will really help you increase logistic and production efficiency and in the end it will bring savings!

Step 1

The current state analysis by DMAIC method

We shall analyse the current state of your company by DMAIC method according to your needs.

• DEFINE

We shall define the process critical areas (KPI's, COPQ, Costs, Losses, Process Flow, VSM, etc.) based on the available data and information. The output report comprises the rough draft of problem solution.

• MEASURE

This phase includes the team defined by partners and our experts, who will carry out detailed data collection for rootcause analysis, process measurements and will prepare the actual VSM and other support steps.

• ANALYSE

All available data then undergo analysis along with preparation of optimal solution. The output VSM includes the future and calculated potential improvements of processes - Calculation of investment and return.

• IMPROVE

We shall analyse the time requirement and cost of implementation on the hardware and software side (connection to enterprise software and infrastructure).

• CONTROL

We shall verify both correctness and process management from the point of view of comparing the input requirements.



LEAN SIX SIGMA

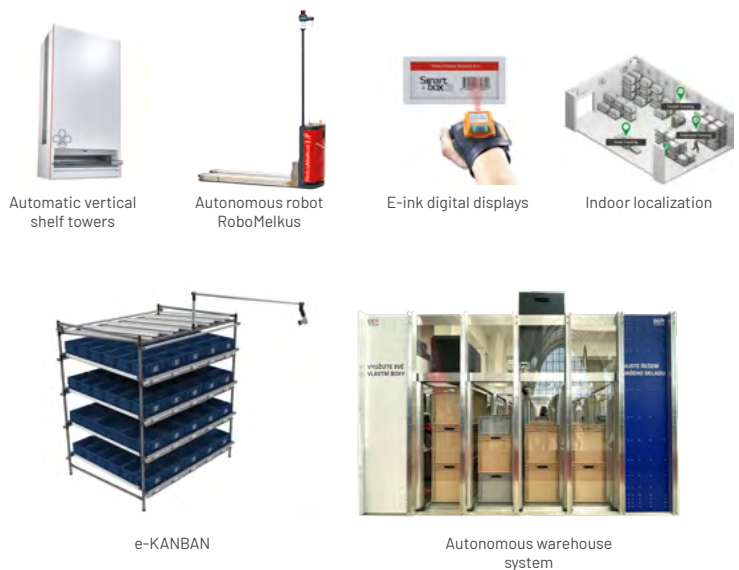

Step 2

Dynamic material flow draft and solution development

To prepare the analyse, we shall propose a solution to meet your requirements, including critical processes improvement in regards to the difficulty and return of investment and, above all, the possibility of expanding the entire solution.

Step 3

"Turnkey" project implementation

Thanks to experience, we can offer the best conditions for delivering the entire project to our clients. This means, that we shall analyse a complete order, design or develop, install and implement the whole solution, which also includes follow-up service.

CASE STUDIES



[THE FULL SCOPE ARTICLE](#)

AGILOX AUTONOMOUS TECHNOLOGY ALSO IMPLEMENTED IN VITESCO TECHNOLOGIES CZECH REPUBLIC

Lean logistics has become a trend having the elements which the production companies are trying to implement into their own operations when needing to save space. Automation interferes with this in a significant way. In Vitesco Technologies Czech Republic, Trutnov, they have implemented the autonomous handling technology. In the company, they are planning a number of other system solutions in the field of storage and transport. For instance, automatic scanning of goods immediately upon receipt has been one of the plans.

IN GREINER PACKAGING, THE AGILOX VEHICLES MAXIMIZED EFFECTIVITY AND SIGNIFICANT SAVINGS

In Greiner Packaging, Louka u Litvínova, where plastic packaging, mainly crucibles for food industry are produced using K1 technology, they focus on intralogistics and process automation. The implementation of four fully automated Agilox vehicles by 4IGV has been one of the last projects bringing the significant savings.

[THE FULL SCOPE ARTICLE](#)



[THE FULL SCOPE ARTICLE](#)



[THE FULL SCOPE ARTICLE](#)

THE AUTONOMOUS VEHICLES IMPLEMENTED IN THE DATART LOGISCIC CENTRE, JIRNY

The Agilox vehicles by 4IGV are currently being put into service in the DATART logistic centre, Jirny, driven by HP TRONIC, Zlín. This system-controlled handling technology in DC6 production facility helps increase effectiveness and safety as part of warehouse operations of different vendors belonging to HP TRONIC Zlín. Specifically, the shipments to DATART and ETA network have been shipped from this distribution centre.

„Must have“



4IGV

Office address:

4IGV s.r.o.

Vlastibořská 2787/5
P3 logistics parks
193 00 Praha 20
Horní Počernice, Česká republika

Billing address:

4IGV s.r.o.

Haštalská 1072/6
110 00 Praha 1
Staré Město, Česká republika
IČO: 11796715

+420 732 603 712

+420 732 170 289

+420 605 750 271

obchod@4igv.cz

www.4igv.cz